

Technical Data Sheet
Filtrate outlet FA-500
Article-No. 80100004

Complete preassembled filtrate extraction unit consisting of:

- self priming permeate pump
- pressure gauge
- frequency inverter
- vacuum pressure sensor

The FA-500 is suitable for filter housing:

MB2-2, MB2-3, MB2-4, MB2-5, MB3-1, MB3-2, MB3-4, MB3-5, MB4-1 MB4-2, MB4-3, MB4-4, MB4-5, MB5-1, MB5-2, MB5-3, MB5-4

Description	Unit	Value
Size of the Pump	L x W x H mm	510 x 190 x 320
Diameter outlet	ISO 228	G2
Diameter inlet	ISO 228	G2
Delivery flow	m ³ /d	50 bis 500
Max. pump capacity at 8 m level difference	L/h	21.000
Filtration pressure	bar	0.1-0.25
Weight	kg	ca. 31
Nominal power	kW	1,2

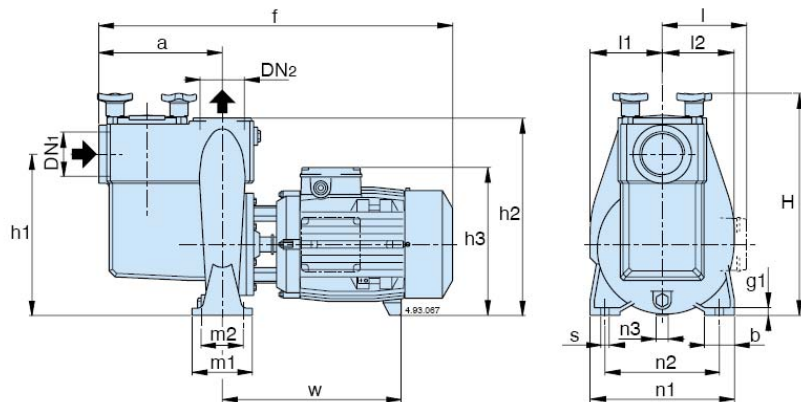

TYP	DN1	DN2	mm																	
			a	f	h1	h2	h3	H	m1	m2	n1	n2	n3	b	s	l	l1	l2	w	g1
B-NMP 32/12AE-DE-FE B-NMP 32/12SE	G 2	G 2	195	510	230	280	210	320	100	70	190	140	30	50	14	-	106	99	220	12